

FAIRCHILD T5420

DIGITAL-PNEUMATIC TRANSDUCER

Installation, Operation and Maintenance Instructions

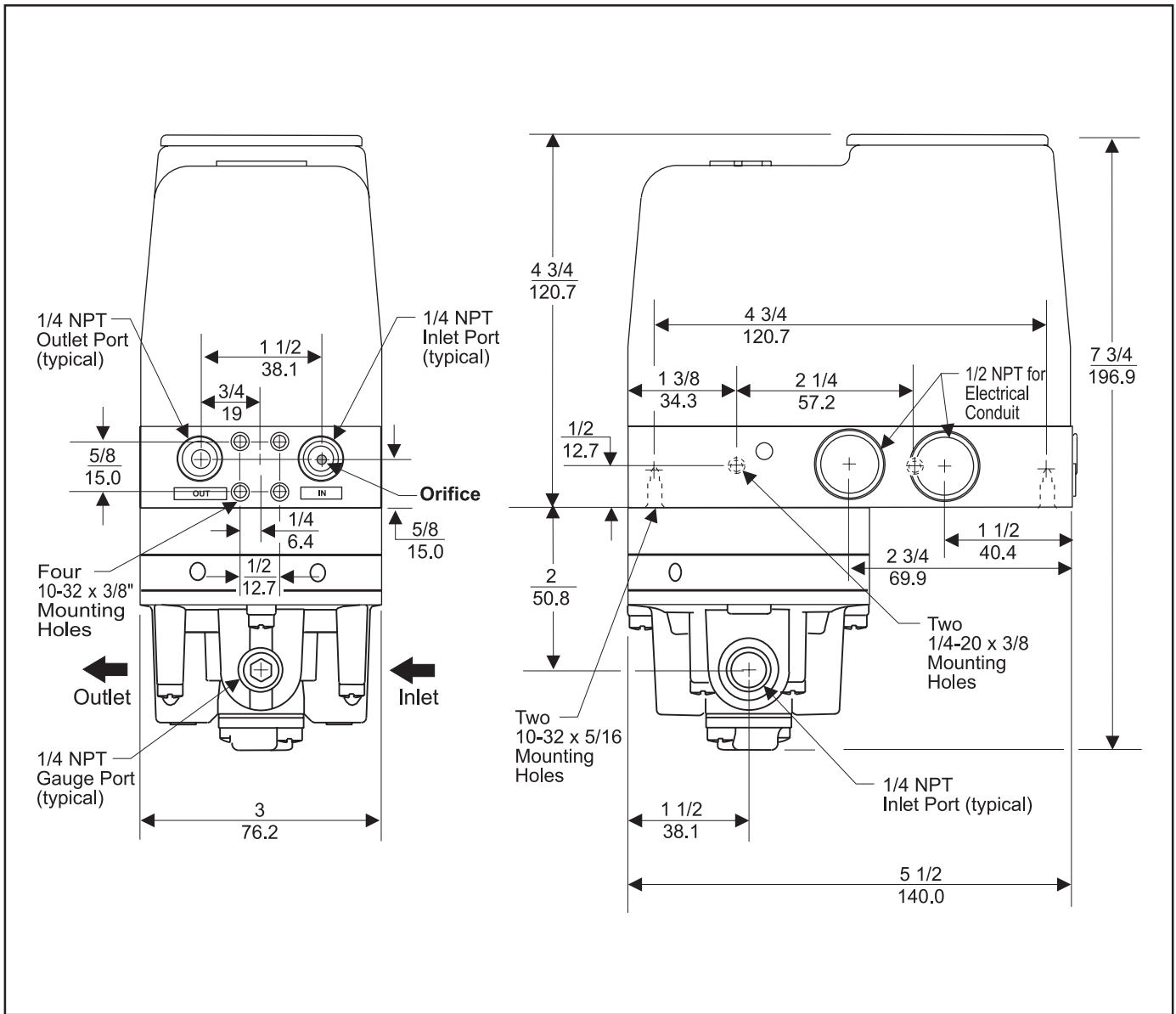

Figure 1. T5420 Outline Dimensions.

INSTALLATION

The Model T5420 can be mounted directly onto a flat surface using the two 10-32 tapped mounting holes in the base of the housing. For more information, see Figure 1. "T5420 Outline Dimensions" above.

The Model T5420 can be Panel Mounted using the mounting bracket supplied in Mounting Kit 15268. For more information, see Figure 2. on page 2.

Installation (continued)

The Model T5420 can be mounted on a 2" pipe using the Optional Mounting Kit 14596. For more information, see Figure 3. below.

NOTE: If the T5420 Transducer is not mounted in an upright position, the Zero & Span Adjustments must be re-calibrated.

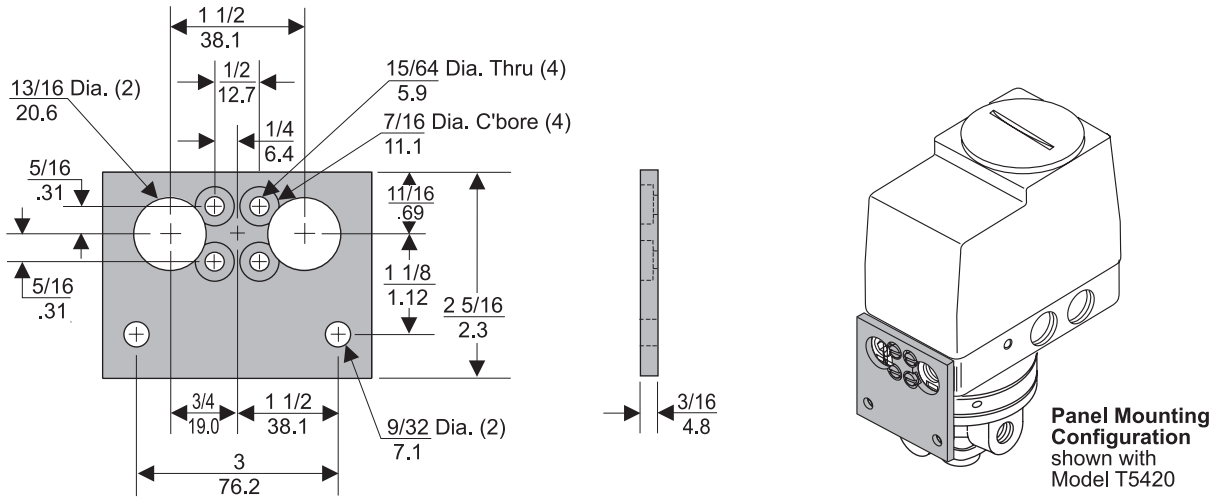

Figure 2. Mounting Kit 15268. (Sold Separately)

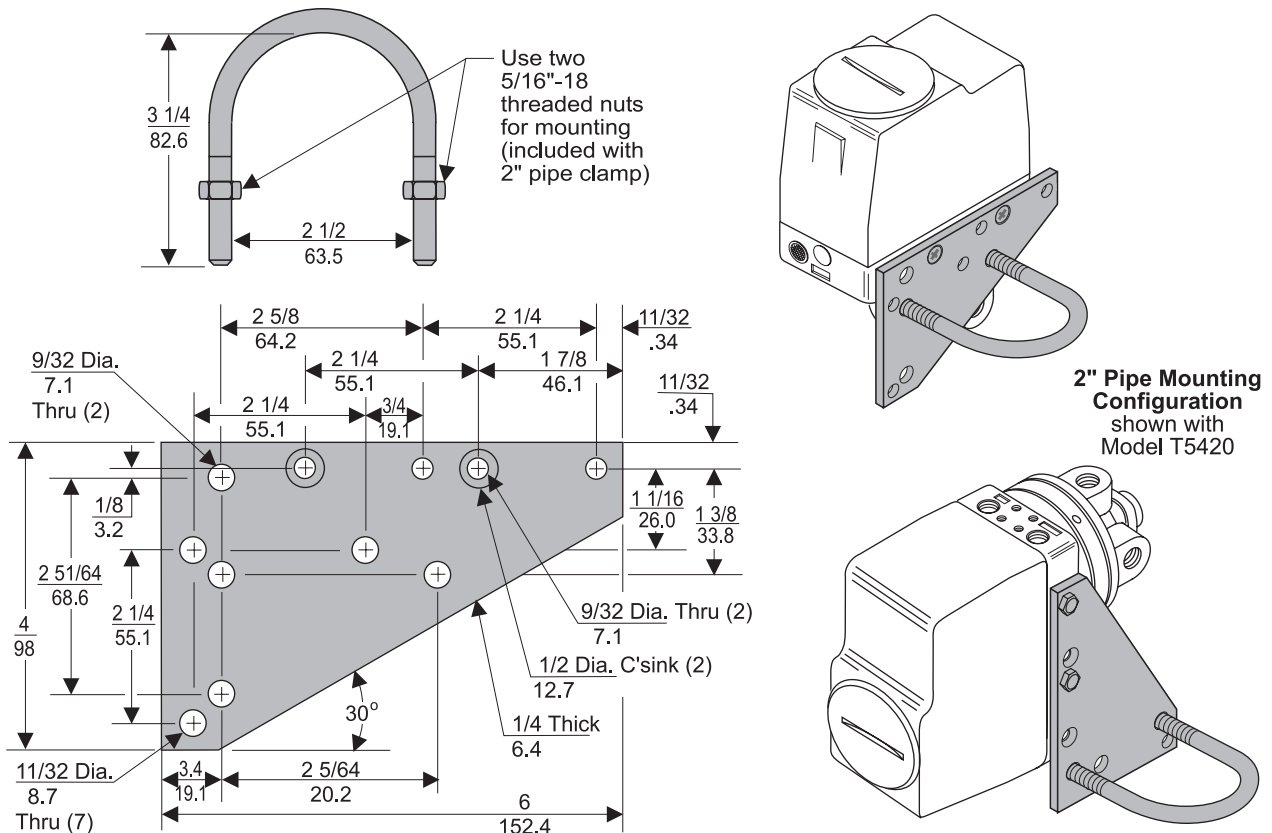

Figure 3. Optional Mounting Kit 14596. (Sold Separately)

Pneumatic Connections

Clean all pipelines to remove dirt and scale before installation.

Apply a minimum amount of pipe compound to the male threads of the fitting only. **Do Not use teflon tape as a sealant.** Start with the third thread back and work away from the end of the fitting to avoid the possibility of contaminating the transducer. Install the transducer in the air line.

The inlet and outlet ports are labeled on the end of the transducer. Tighten connections securely. Avoid undersized fittings that will limit the flow through the transducer and cause a pressure drop down stream. For more information, see Figure 1. "Outline Drawing" on page 1.

NOTES: Instrument quality air, per ISA Standards D7.3-1981, is required. Use a filter to remove dirt and liquid in the air line ahead of the transducer for correct performance. If an air line lubricator is used, it **MUST** be located downstream, beyond the transducer.

The user is responsible for insuring that the environment in which the unit will be installed, and the operating gas, are compatible with the materials in the transducer.

Electric Connection

For the T5420 Transducer, make connections to the Terminal Blocks through the two 1/2 NPT conduit holes as shown below in Figure 4. "Electrical Connections".

CAUTION: Do Not tie *Data Return* from TB2 and *Case Ground* from TB1 together. The *Data Return* **MUST** be taken back to the microprocessor or manual entry device ground to prevent ground loop problems.

For signal lines of six feet or less, use 22 gage wire. For longer signal lines, use 18 gage wire due to voltage drop considerations. Shielded cable **Must Be Used** for the signal lines for noise immunity.

NOTES: To prevent ground loop problems, shield must be connected at the controller end **ONLY**.

The power supply is internally grounded to the transducer housing. The housing should be connected to a good earth ground.

24 VDC Board and 115/230 VAC Board

For 5 Volt Logic Operation, cut jumper W4 and leave VR2. For 15 Volt Logic Operation, cut the Voltage Regulator VR2 and leave W4. For more information, see Figure 4. "Electrical Connections".

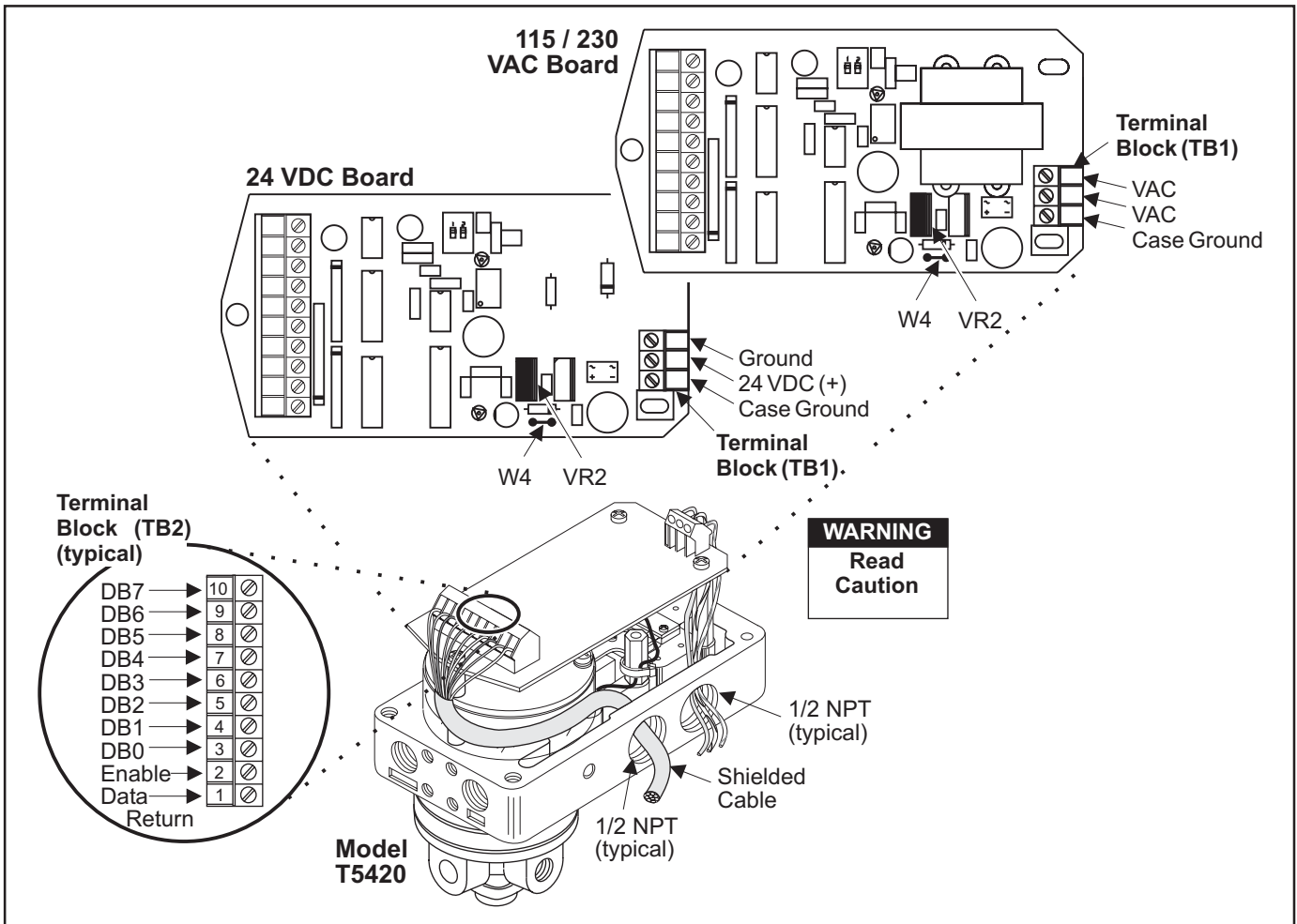

Figure 4. Electrical Connections.

CALIBRATIONS/ADJUSTMENTS

Equipment Required for Calibration:

- Pneumatic Supply capable of delivering up to 50 psig.
- Pressure Gage capable of a digital readout up to 50 psig with an accuracy of 0.1%.

FULL RANGE OPERATION

NOTE: Turn Power off, disconnect data inputs, enable and data return lines.

Forward Acting Mode Adjustment

1. Connect Air Supply and Power Supply to the transducer.
- Forward Acting Calibration-Zero
 2. Set switch SW1-1 to the OPEN position and set switch SW1-2 to the CLOSED position. **Turn Power On.**
 3. Adjust the Zero screw for minimum output pressure. Turn screw counterclockwise to increase pressure and clockwise to decrease pressure.
- Forward Acting Calibration-Span
 4. Set switch SW1-1 to the CLOSED position and set switch SW1-2 to the CLOSED position.
 5. Adjust the Span on the potentiometer for maximum output pressure. Turn screw clockwise to increase pressure and counterclockwise to decrease pressure.
 6. Repeat steps 2-5 until desired output range is obtained.

7. Set switch SW1-1 to CLOSED position and SW1-2 to OPEN position. Unit is now set for high logic input on all channels for maximum output pressure.

Reverse Acting Mode Adjustment

8. Reverse the coil wire connections on the underside of the PC Board as shown in Figure 5. below.
- Reverse Acting Calibration-Zero
 9. Set switch SW1-1 to the OPEN position and set switch SW1-2 to the CLOSED position.
 10. Adjust the Zero screw for maximum output pressure. Turn screw counterclockwise to increase pressure and clockwise to decrease pressure.
- Reverse Acting Calibration-Span
 11. Set switch SW1-1 to the CLOSED position and set switch SW1-2 to the CLOSED position.
 12. Adjust the Span on the potentiometer for minimum output pressure. Turn screw clockwise to increase pressure and counterclockwise to decrease pressure.
 13. Repeat steps 9-12 until the desired output range is obtained.
 14. Set switch SW1-1 to CLOSED position and SW1-2 to OPEN position. Unit is now set for high logic input on all channels for minimum output pressure.

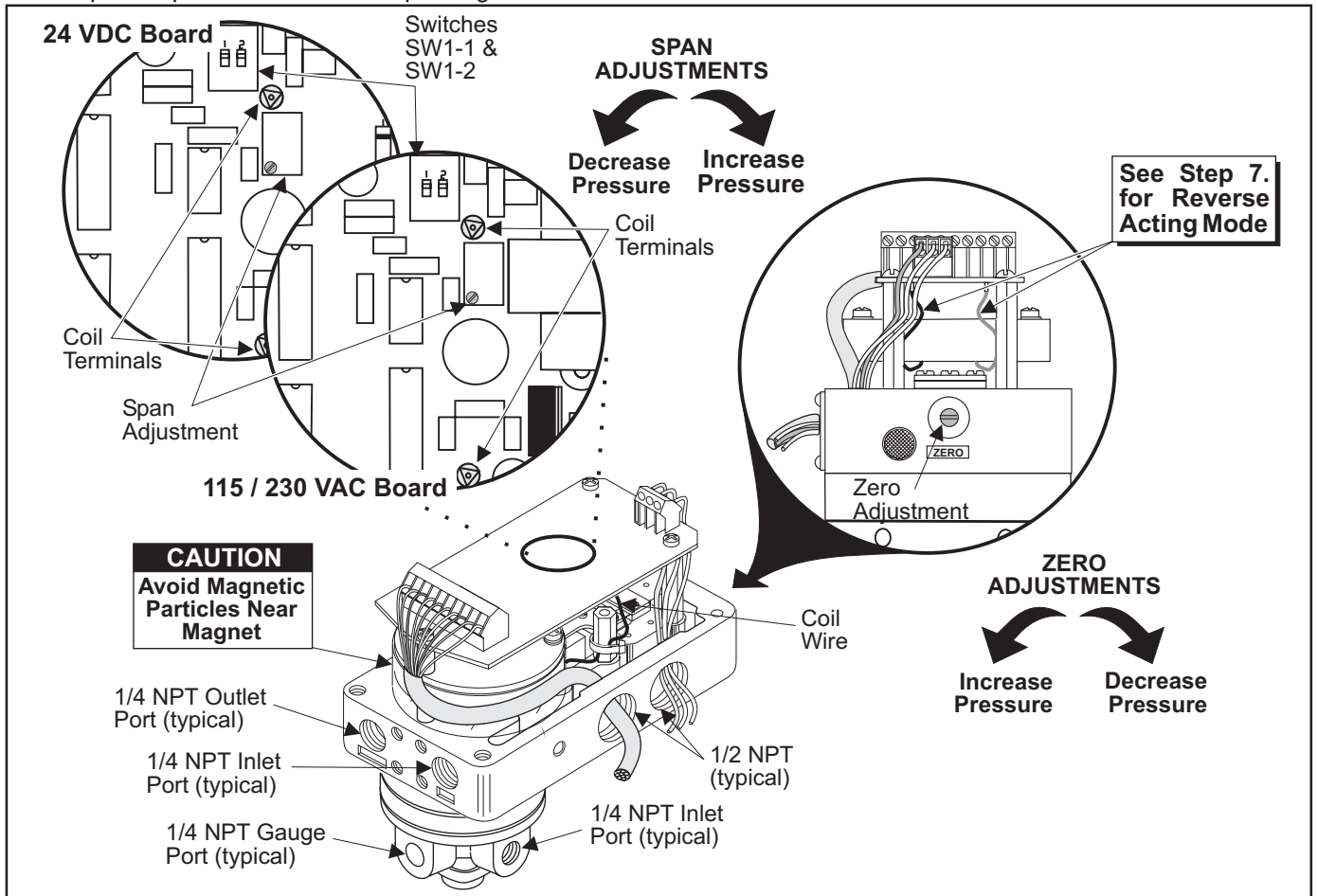

Figure 5. Calibration Configuration.

MAINTENANCE

To clean the Orifice, use the following procedure:

1. Shut off the valve that is supplying air to transducer. **Remove the Air Line and Fitting from Inlet Port.**
2. Remove the Orifice Assembly (9) from the unit by threading a 1/4-20" Screw into the orifice housing and pulling it out through the inlet port. For more information, see Figure 6. "Exploded Drawing" below.
3. Clean with alcohol and dry with compressed air.
NOTE: Parts must be completely dry before reassembling.

To clean the Inner Valve Assembly, use the following procedure:

1. Shut off the valve that is supplying air to transducer. **It is not necessary to remove the Transducer from air line.**
2. Remove Screws (7) holding the Retainer Cap (6) and Plate (5) to Booster (1).
3. Pull out Inner Valve Assembly (4) and wash the seat carefully.
4. Wipe off any particles that may be attached to rubber Seat Ring Assembly (2). For more information, see Figure 6. "Exploded Drawing" below.

NOTE: Avoid such solvents as acetone, carbon tetrachloride and trichlorethylene.

To clear problems caused by Magnet malfunction, use the following procedure:

1. Shut off the valve that is supplying air to transducer. **It is not necessary to remove the Transducer from air line.**
2. Remove Screws (15) and (16) holding Standoff (12) and PC Board (14) to Transducer (8).
3. Remove two Screws (13) holding Magnet (11) to Transducer (8). Remove Magnet (11) and clean gap of any foreign material with masking tape. For more information, see Figure 6. "Exploded Drawing" below.
4. Place Magnet (11) over Coil (10) and tighten with two Screws (13). Using a non-metallic rod, raise up on the arm to make sure Coil (10) is free to move in Magnet (11).
NOTE: If Coil is sticking or dragging, loosen Screws and reposition Magnet then repeat step 4.

To replace PC Board, use the following procedure:

1. Disconnect wires from TB1 and TB2 on PC Board (14). Remove Coil Wires from underside of PC Board (14).
2. Remove Screws (15) and (16) and Standoff (12) holding PC Board (14) to Transducer (8). For more information, see Figure 6. "Exploded Drawing" below.
3. Replace PC Board (14) with the appropriate PC Board from Table 3. on page 6.

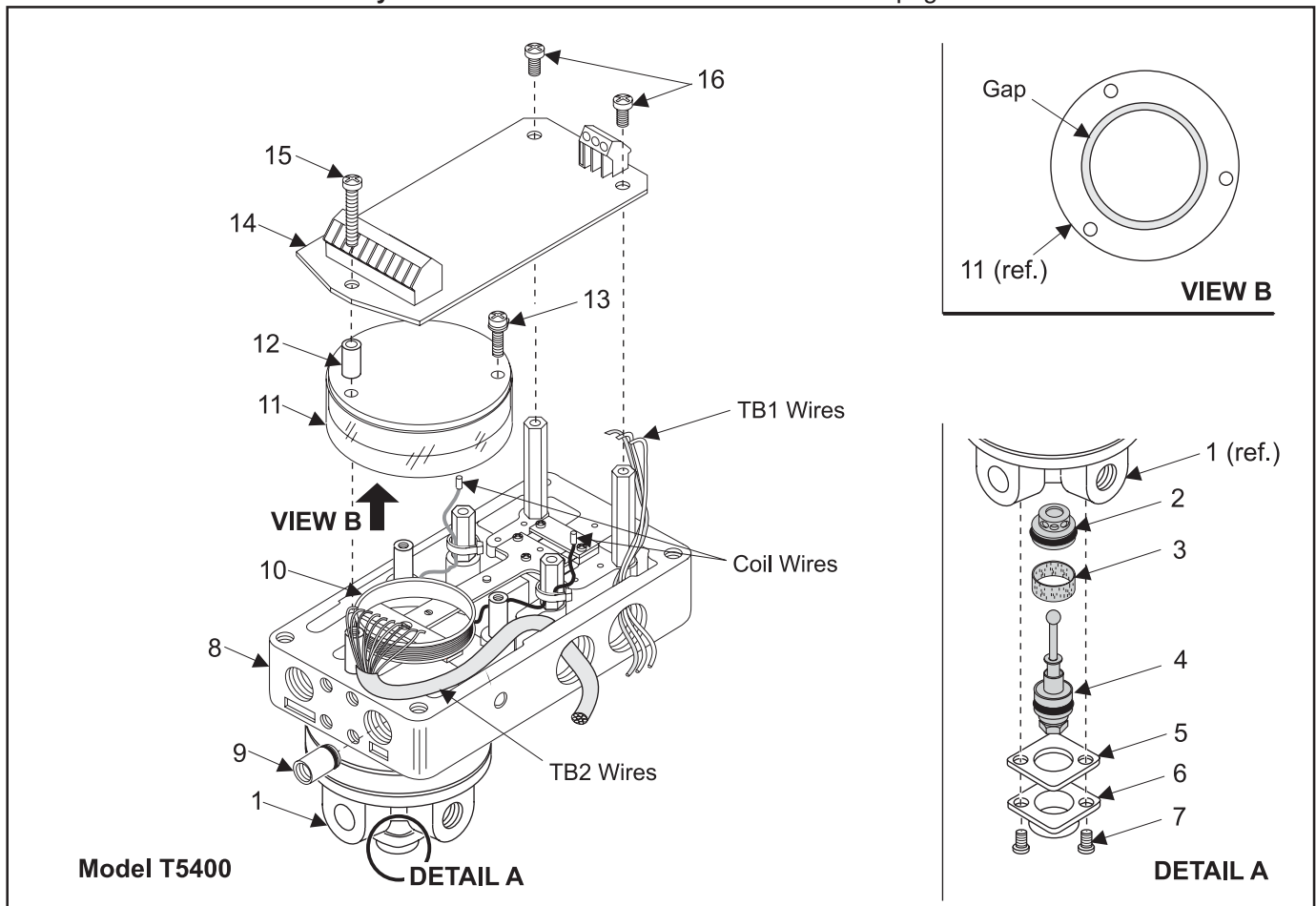

Figure 6. Exploded Drawing.

Maintenance (continued)

Table 3. T5420 Series Components.

Item	Qty.	Part No.	Description
1	1	NS	Booster
2	1	NS	Seat Ring Assembly
3	1	NS	Screen
4	1	NS	Inner Valve Assembly
5	1	NS	Retainer Plate
6	1	NS	Retainer Cap
7	2	NS	Screw
8	1	NS	Transducer
9	1	NS	Orifice
10	1	NS	Coil
11	1	NS	Magnet
12	1	NS	Standoff
13	2	NS	Screw
14	1	044-IPI-109-130 ¹	24 VDC PC Board
14	1	044-IPI-109-110 ¹	115 VAC PC Board
14	1	044-IPI-109-120 ¹	230 VAC PC Board
15	1	NS	Screw
16	2	NS	Screw

¹ For T5420 Units Only.

NS: (Not Serviceable) indicates that the part is not available for field replacement.

TROUBLE-SHOOTING

Table 4. Trouble-Shooting.

Problem	Solution (check)
No Output	Supply Pressure Clogged Orifice Power Supply
Leakage	Pneumatic Connections
Low or Improper Span Adjust	Zero and Span Adjust Supply Pressure Low Output Leakage
Erratic Operation	DC Signal Loose Wires or Connections Liquid in Air Supply Dirt in Magnet Gap
Unit Does Not Operate	Replace PC Board

NOTE: Booster Repair Kits are available for the T5420.

Ratio	Kit Number
1:1, 1:2, 1:3	15288
1:4, 1:5, 1:6	15656

OPERATION LOGIC

After completion of Trouble-shooting, perform the Operation Logic Procedure in Table 5 and 6. For Forward Acting Output Pressure options refer to Table 5. below.

Table 5. Forward Acting Output Pressure

Input Data Bits	High Logic Level Input (SW1-1 Closed)		Low Logic Level Input (SW1-1 Open)	
	Psig	[BAR]	(kPa)	
DB6	6	0.4	40	
DB7	9	0.6	60	
DB6 & DB7	12	0.8	80	
DB7 thru DB0	15	1.0	100	

NOTE: For continuous enable apply ground to enable line or close SW1-2.

For Reverse Acting Output Pressure options refer to Table 6. below.

NOTE: Coil wires on underside of PC board **MUST** be reversed for reverse acting mode.

Table 6. Reverse Acting Output Pressure

Input Data Bits	High Logic Level Input (SW1-1 Closed)		Low Logic Level Input (SW1-1 Open)	
	Psig	[BAR]	(kPa)	
DB6	12	0.8	80	
DB7	9	0.6	60	
DB6 & DB7	6	0.4	40	
DB7 thru DB0	3	0.2	20	

NOTE: For continuous enable apply ground to enable line or close SW1-2.

LEGAL NOTICE:

The information set forth in the foregoing Installation, Operation and Maintenance Instructions shall not be modified or amended in any respect without prior written consent of Fairchild Industrial Products Company. In addition, the information set forth herein shall be furnished with each product sold incorporating Fairchild's unit as a component thereof.

